

VELAN



SECURASEAL

R-SERIES

FOR QUALITY

THAT LASTS



SEVERE SERVICE PERFORMANCE, MADE SIMPLER.

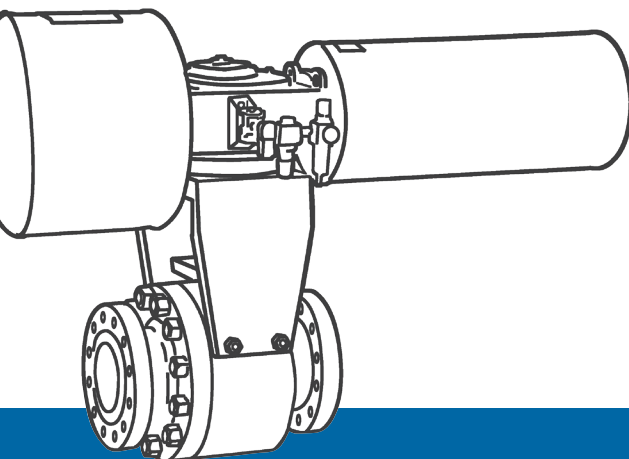

The all new Securaseal R-series cast takes Velan's severe service technology and places it in an optimized package suitable for most process requirements.

For over 30 years, Velan's expertise in engineering state-of-the-art metal-seated ball valves has been put to the service of some of the most demanding projects in the world. For long, Velan has been the "go-to" in developing solutions for the toughest service requirements. Our latest update puts this severe service technology into an optimized package designed to meet the performance, price and delivery requirements of the market.

Velan. Quality that lasts.

SECURASEAL R-SERIES

Designed to perform in a wide range of severe applications, the R-series is rugged and versatile. Carefully engineered and field-tested, it sets a new standard in the industry by offering:

- ▶ An optimized design with a new high quality cast option
- ▶ Strong fugitive emissions performance with standard API 641 and ISO 15848 compliance
- ▶ Superior sealing with fixed downstream seating technology that prevents any unwarranted movements
- ▶ Field-replaceable components providing greater flexibility for potential maintenance

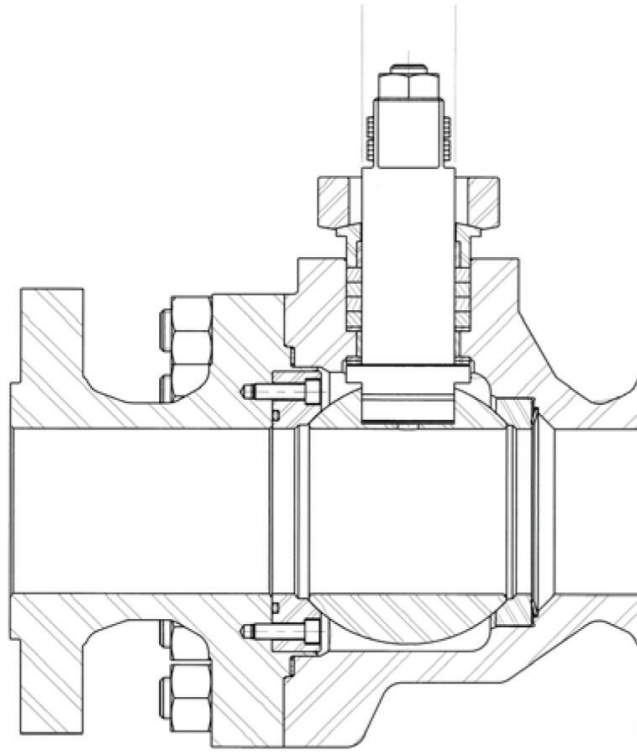

PRODUCT PORTFOLIO

The Securaseal R-series is part of Velan's extensive metal-seated ball valve product portfolio servicing tough applications across industries:

PROCESS SOLUTIONS

R-series Belleville-loaded sealing for severe corrosion, erosion and temperature resistance.

X-series graphite-loaded sealing for high solids concentrations.

STEAM SOLUTIONS

Q-series Power Ball valves for high pressure/temperature steam.

COKING SOLUTIONS

Complete series of valves and automation technology for **delayed coking** and applications prone to coke build-up, including switching, isolation and back pressure control.

ENGINEERED SEVERE SOLUTIONS

Extensive series of valves for **severe applications** including high pressure/temperature slurries, high solids concentration, fast cycling, extreme temperatures, hydrometallurgy, and more.

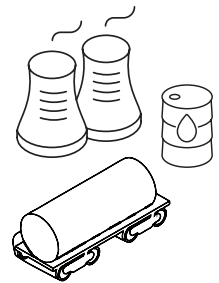
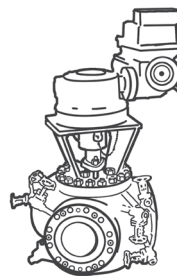
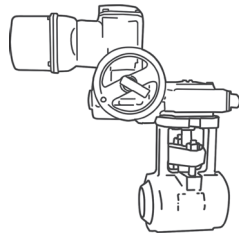
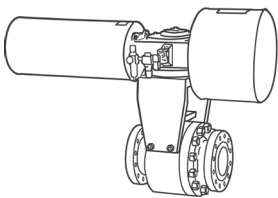

CONTACT US TO FIND OUT HOW WE CAN SOLVE YOUR PROCESS CHALLENGES

FLY-SRC-04-18

velan.com • sales@velan.com