

A step forward in control valve actuation

In March, Velan ABV announced it had successfully shipped four complete control units that represented a major step forward in control valve technology, as they combine the Key-C rotary control ball valve with a unique Cable Drive actuator. Time to put some questions to Velan ABV Product Manager, Mr. Nicola Lucchesi.

By David Sear



Mr. Lucchesi, what exactly did Velan ABV deliver and to whom?

We shipped four 30" Class 300 control valves to be part of the gas treatment process for a modernization project of a large-scale refinery in northern Kuwait. We believe that the Key-C valve – which was developed from a traditional trunnion ball design - represents the new generation of rotary control ball valves as it matches high performance with wide flow capacity.

How have you made the standard ball valve suitable for control applications?

The ball is equipped with a special caged trim – this multi-stage technology limits the chance of cavitation or flashing phenomena in liquid applications and reduces the aerodynamic noise in presence of gas flow. The design allows for optimal flow regulation in all critical conditions. This valve typology is extremely suitable in services requiring high rangeability combined with very high differential pressure between

CONTROL VALVES

upstream and downstream. The caged trim allows traditional ball valves to evolve into high performance control valves. The caged trim is composed of a series of drilled plates located inside the ball bore, having the goal to partialize the pressure drop; as a result of this effect the system is able to reduce the chance of cavitation or flashing phenomena and allows a sensible noise reduction.

How does your valve compare in terms of rangeability?

Rangeability is defined as the ratio between nominal flow coefficient C_v and minimum controlled C_v by the valve. For standard control valves, a good target of rangeability can be 50/1. Thanks to its special trim, our valve is suitable for applications requiring a value of rangeability up to 300/1.

How would you sum up the advantages of your control valve?

Firstly we can speak of the very high capacity and rangeability. Then there is the compact package: rotary valves offer much smaller sizes within the same C_v range in respect of the conventional control valves (globe). We believe that the service life will also be longer: the rotary shaft provides much longer stem seal life and less emissions on the environment. There is also a low risk of erosion/corrosion. This is thanks to the axial flow path and the absence of restrictions of the vena contracta also at minimum flow conditions. Other benefits include low noise & better vibration resistance, low operating friction and ease of installation.

What is so special about the actuator?

The success of this project can be attributed to the innovative Cable Drive actuator, able to overcome the traditional drawbacks of a Scotch Yoke design in fast and demanding control conditions. Patented in 2014, its high efficiency transmission system develops a linear torque and ensures

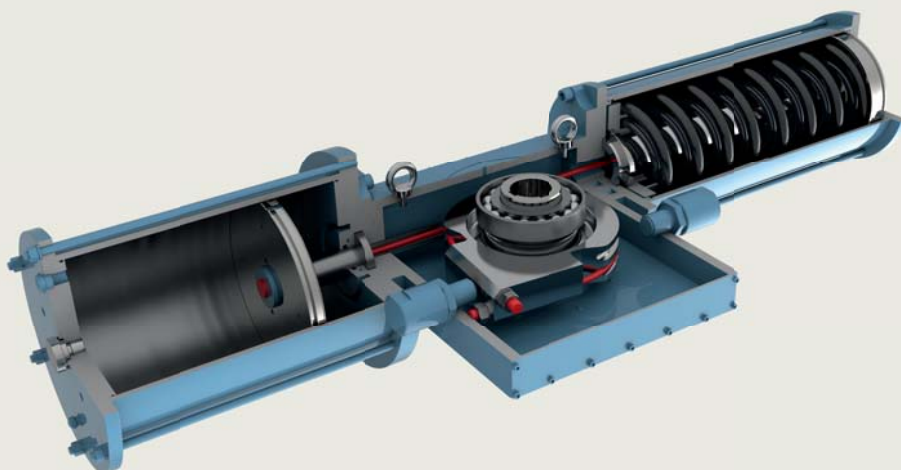

Cutaway showing the innovative design of the Cable Drive actuator.

low friction and zero backlash along the entire stroke. These key features enable accurate and precise control in high dynamics process.

This unique combination has been found to meet challenging project requirements. For example, during the functional tests, each 30" valve completed the entire stroke, in control mode, in less than 12 seconds and at the same time guaranteed a step response with a maximum overshoot of 0,4%, a dead time of 0,5 seconds and an accuracy of 0,6%. This is a true achievement in control valve actuation.

Can you compare the Cable Drive system to the typical Scotch Yoke?

Scotch Yoke actuators are most often used for on-off rotary valves, but they are limited if the intended service includes accurate control, fast-closing operations and/or heavy-duty cycles. The Cable Drive actuator's design overcomes these limitations, guaranteeing optimal position control in the most demanding conditions.

Have you performed any tests that back up these claims?

Yes, we have run a dynamic performance comparison with a ball control unit, first actuated with the Cable Drive actuator and



Close-up of the special caged trim in the Key-C rotary control ball

then with a standard Scotch Yoke actuator. The tests on these two systems have been executed in accordance with the standard ISA 75.25.01 "Test Procedure for Control Valve Response Measurement from Step Inputs".

Three separate tests, namely a baseline test, a small step test and a response time test, have been conducted twice on both units to quantify how much better and faster the unit equipped with the Cable Drive actuator is in responding to an input signal. During the first implementation the control loop parameters have been tuned to match a low demand control mode. Instead, during the second, they have been tuned to maximize the achievable performance. In both cases, the major time constants, the maximum overshoot, the dead band, the accuracy and the resolution have been registered and compared.

One of the clear conclusions is that, when the control loop parameters increase to reach high dynamics, the Cable Drive solution performs significantly better, showing greater performances and less instability.

Meet Nicola Lucchesi

Nicola Lucchesi received his degree in Mechanical Engineering in 2004 at the University of Pisa, Italy. After a Ph.D experience in Robotic Automation at the PERCRO Lab. of S.S. Sant'Anna Pisa, he joined Velan ABV in 2009 with the role of R&D manager with the task to optimize the design of actuated valves for critical and control services, equipped with pneumatic and hydraulic accessories. He is the inventor of two patents for Velan and the author of several articles. In 2012 he was appointed the head of a three year project, co-financed by the Regional Government of Tuscany, in partnership with the University of Florence with the goal to develop 'High Efficiency Valves'. In 2016, he was promoted to Product Manager.

